

FREEZER | Freezer a pozzetto

CONGELATORI A POZZETTO ► TOP VETRO

CFG 308



DETTAGLI



Ruote incluse nell'imballo (Da assemblare)



Termómetro digitale



Serratura di serie



Cestelli di serie



Unità vista dall'alto



CARATTERISTICHE GENERALI

Congelatore a pozzetto 300 Lt con top in vetro scorrevole	•
Acciaio verniciato bianco per esterno ed interno	•
Refrigerazione statica	•
Sbrinamento manuale	•
Termómetro digitale	•
Schiumatura in Ciclopentano (60mm di spessore per lato)	•
Singolo vetro temperato di sicurezza	•
Maniglia inclusa nella cornice del vetro	•
Serratura di serie	•
Ceste incluse (N.3 Pcs)	•
N.4 Ruote (N.2 Frontali provviste di freno)	•
Classe energetica: D	•

SPECIFICHE TECNICHE

Capacità	300 L
Temperatura	C1 (-18°C)
Consumo	1.776 kWh/24h
Potenza Nominale	179 W
Rumorosità	52.3 dB(A)
Peso Netto	56 Kg
Peso Lordo	70 Kg
Dimensioni Esterne (LxPxH mm)	1014x635x863
Dimensioni Interne (LxPxH mm)	890x510x659
Dimensioni Imballo (LxPxH mm)	1100x750x860
Quantità di carico 20'/40'/40'HQ	30/64/96

CERTIFICAZIONI

CE RoHS

INGOMBRO PRODOTTO

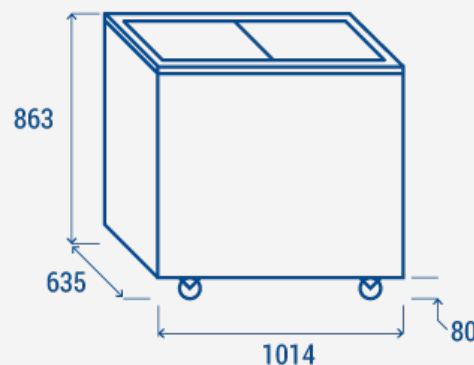

COOL HEAD EUROPE
We make the world a cooler place



www.coolheadeurope.com